

**FRONT VIEW**

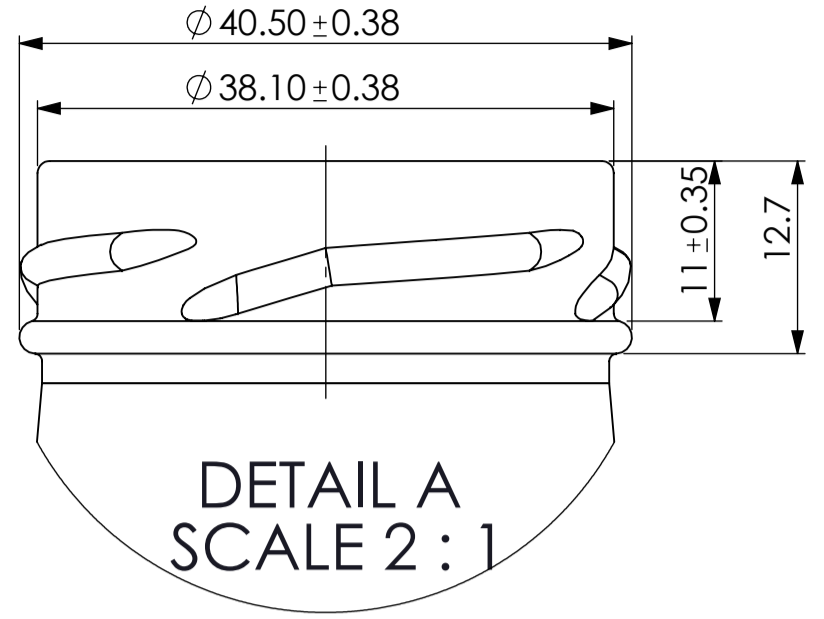

**DETAIL A  
SCALE 2 : 1**

**43 MM LUG SPECIAL**

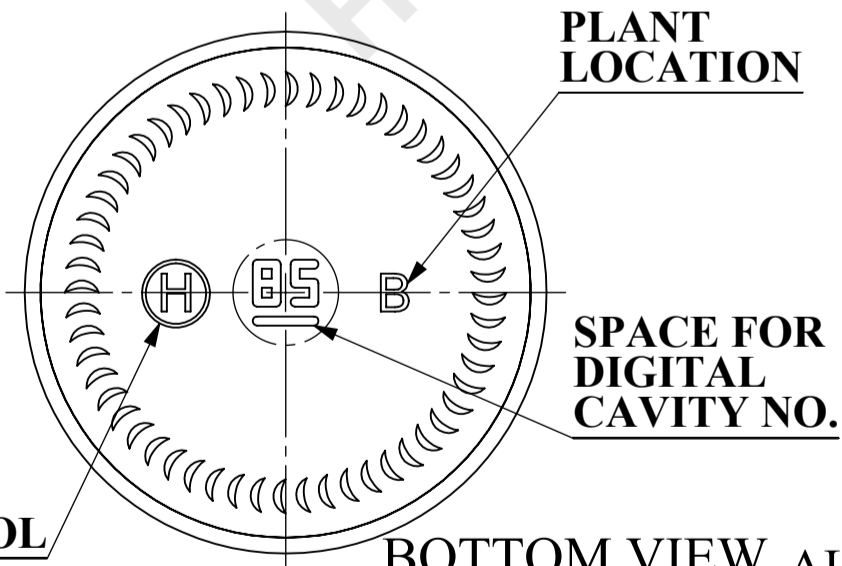

**BOTTOM VIEW ALL DIMENSIONS ARE IN MILLIMETERS**



<b>PROCESS</b>	<b>B&amp;B</b>									SPECIFICATION AGREEMENT ARE BASED ON TOLERANCED DIMENSIONS ONLY DO NOT SCALE DRAWING COPYRIGHT RESERVED. NOT TO BE COPIED IN WHOLE OR PART WITHOUT WRITTEN PERMISSION FROM H.N.G. & I. LTD.		
<b>MINIMUM THROUGH BORE</b>	-										<b>HINDUSTHAN NATIONAL GLASS &amp; IND. LTD.</b>	
<b>FILL POINT VERIFIED</b>	--											
<b>TILT ANGLE</b>	-	No.	REV.No.	<b>REVISION</b>			<b>DATE</b>	<b>CHK</b>	<b>DRC</b>			
<b>MAXIMUM DEPTH OF STANDARD ENGRAVING</b>	-	<b>FILL-POINT</b>		-							<b>TITLE</b>	500 ML ROUND 43MM LUG BOTTLE
<b>MAX. GAS VOLUMES</b>	-	<b>BRIMFUL CAP.</b>		<b>520 ± 7 ML.</b>							<b>CUST</b>	COMMON MARKET BOTTLE
<b>REF DRG No :- W1-01036</b>		<b>WEIGHT</b>		<b>240 ± 20 GMS.</b>							<b>DRN</b>	Sandeep
<b>MOULD EQUIPMENT ORDERED BY</b>		<b>FINISH</b>		<b>43 MM LUG SPECIAL</b>							<b>DR. DT.</b>	16.08.2012
<b>PLANT</b>	B	<b>SURFACE TREATMENT</b>		NO							<b>CHK. DT.</b>	
											<b>APPD.</b>	<b>APPD. DT.</b>
											<b>COLOUR</b>	FLINT
											<b>C.C. NO.</b>	HNG-00420
											<b>DRAWING No.</b>	HNG-00420
												A3 REV.